

- NOTES -

1. MATERIAL: STEEL.
2. FINISH: HOT DIP GALVANIZE PER ASTM A153.
3. CATALOG NUMBERS WITH A "USA" SUFFIX HAVE ALL COMPONENTS MELTED AND MANUFACTURED IN THE USA.

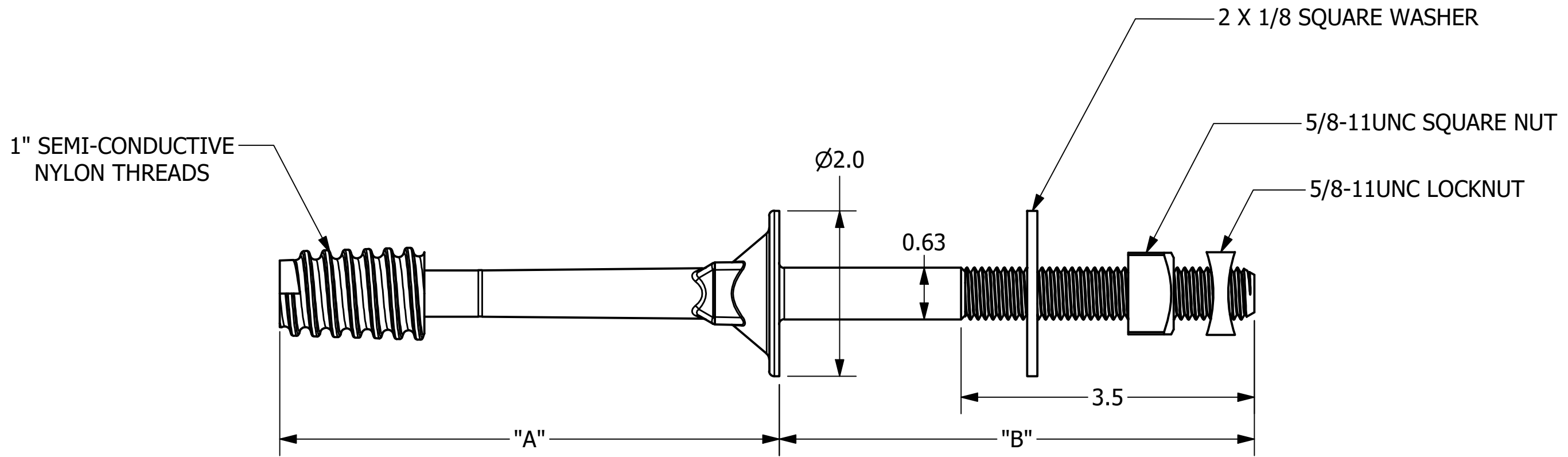

CATALOG NUMBER	USA CATALOG NUMBER	"A"	"B"
881P		5	5.75
881AP	881APUSA	5	6.5
883P	883PUSA	6	6.5
884P		6	5.75
T2060610P		6	7.5

<h1>CHANCE[®]</h1>	HUBBELL POWER SYSTEMS, INC.			
	TITLE NYLONG THREAD FORGED LV PIN			
CONFIDENTIAL: THIS DRAWING AND ITS CONTENTS ARE CONFIDENTIAL AND THE EXCLUSIVE PROPERTY OF HUBBELL POWER SYSTEMS. NO PUBLICATION, DISTRIBUTION, OR COPIES MAY BE MADE WITHOUT THE WRITTEN CONSENT OF HUBBELL POWER SYSTEMS. HUBBELL POWER SYSTEMS UNPUBLISHED ALL RIGHTS RESERVED UNDER THE COPYRIGHT LAWS.	SIZE B	CAT / PART / ASSY NO. SEE TABLE	DWG NO. SA881P	REV D
DO NOT SCALE THIS DRAWING	DRN BY TOLIVER	DATE 9/17/20	SHEET 1 OF 1	